

# Neutral Wire Facts and Mythology

White Paper #21

**APC**<sup>®</sup>  
Legendary Reliability<sup>®</sup>

## Executive Summary

This Technical Note discusses many common misunderstandings about the function of the neutral wire and its relation to power problems. The subjects of dedicated lines, phase reversal, isolation transformers, and grounding are addressed. Various myths are described and criticized.

# Background

In the normal three wire single phase power system found in most offices, the "Neutral" wire is one of the three connections at the wall outlet. Some semi-technical articles and advertising literature for power protection products attribute "special" properties to this wire. Frequently misleading claims are made regarding the function of this wire and how it is used by electronic equipment. Sometimes, power protection equipment is sold on the basis of claims involving special treatment of the neutral wire.

## Facts: Characteristics of the 3-wire system

A typical office wall outlet has three electrical connections, which are the "hot", "neutral", and "grounding" wires. All office equipment requires only the hot and neutral wires to function. The third or grounding wire is connected to exposed metal parts on the equipment. Within the building, the grounding connections of all electrical receptacles are wired to one another and are connected to the water piping. This ensures that all electrical equipment with exposed metal parts has these parts electrically connected to each other and to exposed metal fixtures in the building such as water fixtures (see the appendix: "the origin of the 3-wire system"). The wiring system is diagrammed in figure 1:

**Figure 1: The 3-wire system**

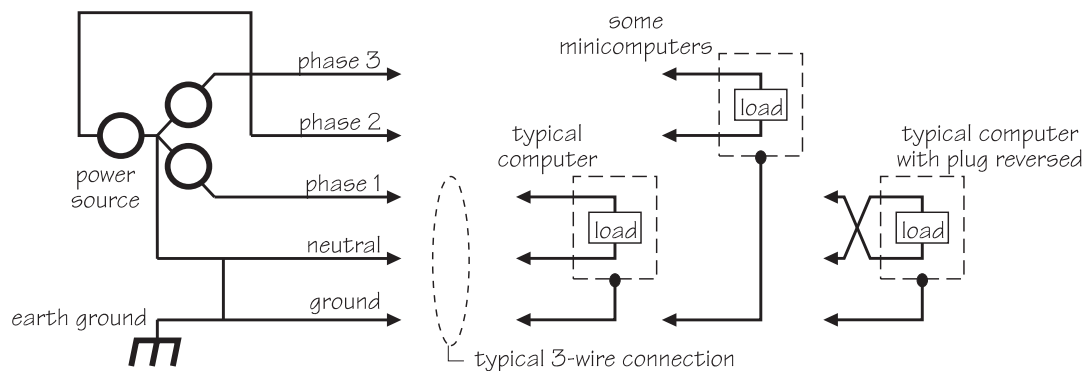

The hot and neutral wires are interchangeable as far as the equipment is concerned. Both are power carrying wires. One of the power carrying wires is grounded at the source for reasons of safety (see the appendix: "the origin of the 3-wire system"). The only reason why the two wires are differentiated (hot vs. neutral) is to identify which of the wires is grounded (the neutral wire).

The 3-wire system that the user sees is actually derived from three phase distribution, which uses a 5-wire system. In the 5-wire system, there are 3 hot wires, 1 neutral wire, and 1 grounding wire. The common 3-wire receptacle uses only one of the 3 hot wires.

In North America, minicomputers frequently are designed to use a 208V 3-wire system. In this 3-wire system there are 2 hot wires and 1 ground wire (no neutral wire). In this case the two hot wires are the power carrying wires.

In Europe, the normal 3-wire receptacle is symmetrical so that the neutral and hot wire connections can be swapped by simply rotating the plug.

## "Ed" and "Ing"

In North America, much of the confusion regarding grounding has its roots in the National Electrical Code of the United States. In the Code, the receptacle ground connection is referred to as the "Grounding" conductor while the neutral connection is referred to as the "Grounded" conductor. The subtle difference between "ing" and "ed" has led many to erroneously interchange these terms in the literature.

The chief error, which occurs, is that real problems which are caused by problems with the ground"ing" wire such as Inter-System Ground Noise are improperly attributed to the ground"ed" wire. The result is that users sometimes purchase power protection equipment that is not designed to solve the problem that they are attempting to prevent (Inter-system ground noise is discussed in APC White Paper #8).

The most common example of this mistake is the purchase of a plug-in isolation transformer to solve a problem with ground loops or Inter-System Ground Noise. Isolation transformers have absolutely no affect on these problems because they are required to pass the ground"ing" wire straight through. Isolation transformers are frequently represented as providing an "isolated ground". What they actually provide is an isolated neutral or ground"ed" wire. This provides no benefit in solving ground"ing" problems, which are the primary cause of power problems.

## Special issues in North America

The Neutral and hot wires are interchangeable and reversible insofar as the operation of equipment is concerned. This leads to the questions as to why in North America one of the power prongs is slightly different in size from the other. A natural but wrong conclusion is that proper "polarization" is important to the proper operation of equipment.

The actual answer as to why plugs are polarized in North America is found in a ubiquitous appliance: the screw-in incandescent lamp. This appliance, standardized long ago, violates many modern safety regulations but is too common to outlaw. The power connections to the bulb involve the threaded socket and the recessed "button" at the bottom of the socket. The only reason why the prongs on the two prong plug are different sizes is to ensure that the more dangerous connection, the more accessible threaded socket, is always connected to the neutral, or safer, wire. All modern two prong appliances and office equipment are designed so that they can be plugged in either way and they just use the standard plug, which happens to have the differently sized prongs.

## What is a dedicated line?

A dedicated line is a power line, which runs from the circuit breaker panel to the critical load and has no other loads connected to it. Normally a circuit breaker feeds multiple receptacles; with a dedicated line, a single circuit breaker feeds only the one receptacle that the protected load is connected to. The advantages of a dedicated line are threefold:

First, the protected load is not subjected to input voltage variations that could be caused by other loads sharing the same circuit. Such variations could result from the voltage drops in the building wiring, which are caused by the currents drawn by the adjacent loads. These variations are prevented by the dedicated line since the adjacent loads no longer share the same building wiring.

Second, the protected load is not subjected to variations in the voltage of the grounding wire, which might result from ground noise injection from adjacent loads. This reduces Inter-System Ground Noise.

Third, the protected load is not subject to the potential hazard of having its source circuit breaker tripped by the malfunction of another load, since with a dedicated line no other load shares the same circuit breaker. A dedicated line may be installed at any time. An electrician simply installs a new circuit breaker in the circuit breaker panel and runs a new wire to either a new or existing AC receptacle.

When a UPS is used with the critical load, the voltage regulation and circuit breaker tripping prevention features of the dedicated line are rendered unnecessary. The benefits of the dedicated line in reducing Inter-System Ground Noise cannot be accomplished by a UPS or any other power conditioning equipment. Only proper interconnection of computer equipment can offset the problems of Inter-System Ground Noise (see APC White Paper #8).

## Neutral wire mythology

There are a number of myths related to the neutral wire and they are described:

**Myth: Computers require a "clean" neutral wire connection to operate.**

Many computers do not even have a neutral wire connection! Large servers and routers do not have a neutral connection. These computers derive their power from two hot wires.

In Europe, there is a neutral connection in most countries, but the plug is designed so it can be swapped with the hot wire by simply rotating the plug. Therefore, the computer does not even know which of its input wires will end up connected to the neutral wire and which will be connected to the hot wire.

**Myth: The neutral wire is used as some kind of reference for computer logic.**

All safety agencies such as UL and TUV stipulate that such a connection is not allowed. In fact the rules state that there can be no connection or circuit of any kind and that there must be at least 1/2 cm of physical space between any logic reference and either the neutral or hot wires.

**Myth: A computer treats the neutral wire differently from the hot wire.**

International office product safety regulations (including IEC 950 and UL 1950) prohibit these wires from being treated differently. Each is considered a safety hazard under the regulations and is required to be disconnected from and have appropriate safety spacings from logic circuits. Furthermore, inspection of the wiring schematics of any computer equipment clearly shows that the input hot and neutral wires are connected to the same circuits in the same ways and are interchangeable. Belief in this myth is very uncommon in Europe since anyone can see that a European plug can be reversed.

**Myth: Grounding problems or loops can be corrected using an isolation transformer.**

International office product safety regulations including IEC 950 and UL 1950 require that an isolation transformer is only allowed to isolate the hot and neutral wires; the grounding wire must be passed straight through. Since the computer circuits including data communication circuits are connected to the grounding wire and not the neutral wire, the isolation transformer or any power conditioner or UPS with an isolation transformer has absolutely no effect on computer grounding problems.

**Myth: Noise on the neutral wire couples into computer circuits.**

International office product safety regulations including IEC 950 and UL 1950 prohibit any intentional circuit coupling between power wiring and computer circuits. However, unintentional coupling may occur through radiation, just like radio interference. Such coupling would not be different from the neutral wire than it would be from the hot wire. The frequencies at which such electromagnetic coupling could act would necessarily be at wavelengths comparable to or shorter than the physical size of the computer or network: many tens of millions of cycles per second (MHz). Reduction of such interference can be accomplished by radio frequency common mode filters.

**Myth: The purpose of a dedicated line is to solve problems with the neutral wire.**

The purpose of the dedicated line is not related to the neutral wire see earlier section for explanation of the dedicated line).

First and most importantly, the dedicated line ensures that no other loads share the same two power wires. Other loads, if connected, might draw currents that could cause voltage drops in the building wiring that supplies the critical load. The dedicated line reduces variations in the supply voltage to the protected equipment by eliminating the effect that other equipment connected in parallel might have.

Secondly, the dedicated line ensures that no other loads share the same grounding wire. Other loads, if connected, might inject noise into the shared grounding wire, causing the grounding connection voltage at the critical load to be different from the voltage at the circuit breaker panel. This problem is called Inter-System Ground Noise (see APC Tech Note #T8) and can cause disruptions in data communication and

even damage of user equipment. The dedicated line reduces Inter-System Ground Noise at the protected equipment by eliminating the effect that other equipment connected in parallel might have.

**Myth: An isolation transformer serves the same function as a dedicated line.**

An isolation transformer does not regulate the incoming line and therefore does not provide the main function provided by a dedicated line. An isolation transformer is not permitted by safety regulations to interrupt the grounding wire. Therefore the transformer cannot provide any reduction in Inter-System Ground Noise, which a dedicated line can provide.

An isolation transformer does provide surge protection, which a dedicated line does not provide. An isolation transformer does eliminate any noise between the neutral wire and the grounding wire. Most of this noise is NOT removed by a dedicated line because it is not caused by other loads but rather from radio frequency pickup, which occurs whether or not, the line is dedicated. Therefore, the dedicated line and the isolation transformer do not have common functionality.

**Myth: Common mode noise is a grounding problem.**

Common mode noise is the noise between the power carrying wires and the ground wire. The presence of a neutral wire is not required (many computers do not have a neutral wire connection). Grounding problems only exist in computer installations when two separate pieces of grounded equipment are interconnected through data communication lines. The correct term for "grounding problems" is "Inter-System Ground Noise". Common mode noise and Inter-System Ground Noise are separate phenomena, which have completely different effects on equipment and are affected by different types of power protection equipment.

## The origin of the 3-wire system

A principal goal of power system design is to make sure that any user who touches the exposed metal surfaces of two pieces of equipment at once will not be subjected to an electrical shock.

A shock hazard is caused when two exposed metal surfaces have different voltages. The most common type of shock hazard occurs when the hot wire or circuits connected to the hot wire accidentally come in contact with an exposed metal part of some piece of equipment.

Electrical power flows in the form of current, which must pass through the equipment and then return to the power source. Therefore, it is convenient to think of one wire to the load being the "source" wire and one being the "return" wire. This simple model is appropriate for DC systems but does not work for an AC system because the flow of the power is continually reversing direction with a frequency of 50 or 60 times per second. From the point of view of the equipment or the power source, the source and return wires are constantly being interchanged. In fact, no equipment can tell which wire is which! It is easily demonstrated that the two power wires to any piece of AC equipment can be interchanged without any affect on function. In fact, in Europe, unlike North America, the plug on a piece of equipment can be plugged in either way! (The asymmetrical offset ground pin on the North American 3-wire outlet makes it impossible to reverse the

connection of the two power wires). This fact of symmetry seems to be at odds with the distinct labeling of the AC power wires as "hot" and "neutral".

The reason that one of the power wires is named "neutral" is because it is connected directly to the building ground connection at the circuit breaker panel. Therefore it is connected directly to the grounding (third) wire. In essence, then, two of the three wires at the wall receptacle are actually grounded wires, one being used for power flow, and the other connected only to exposed metal parts on the equipment. The power wire that is grounded is called the "neutral" wire because it is not dangerous with respect to exposed metal parts or plumbing. The "hot" wire gets its name because it is dangerous.

The grounding of the neutral wire is not related to the operation of electrical equipment but is required for reasons of safety. To reduce the chance of electrical shock, it is important to provide a means to automatically shut down the electrical circuit if an exposed metal part becomes accidentally connected to a hot conductor or circuit. This is accomplished using the 3-wire system by an ingenious technique:

Every electrical circuit is protected by a circuit breaker. The purpose of the circuit breaker is to prevent the building wiring from overheating as a result of excessive user loads being plugged in. However, in the 3-wire system, the circuit breaker provides another critical safety function. If a hot wire or circuit were to become accidentally connected to an exposed metal part on a piece of equipment, then a shock hazard would exist. However, if the exposed parts are connected to the grounding wire, then the hot wire becomes connected to the grounding wire. This would not cause anything unusual to happen except for the fact that the second power wire, the neutral wire, is also connected to the grounding wire at the circuit breaker panel. Therefore, for this safety hazard the grounding wire essentially becomes connected as a load. The low resistance of the grounding wire causes it to draw a very large amount of current when it becomes inadvertently connected as a load, which in turn causes the circuit breaker feeding the hot wire to trip. Therefore, the 3-wire system operates in a manner which transforms a safety hazard into an over current condition, causing the safety hazard to be automatically cleared by the circuit breaker. The circuit breaker is used as both an over current protector and a shock hazard protector.

## Conclusion

The neutral wire is associated with many misunderstandings and myths related to power quality. In fact, the neutral wire and the hot wire are interchangeable from the point of view of protected equipment. A proper understanding issues associated with the neutral wire can help to ensure that power system designs are implemented for the right reasons.